

Art. No.	Nominal Dimension My	Length L mm	(M X)	Ø d1 mm	h mm	Ø A mm	Ø B mm	C mm
0663 4 60*	M 4	6.0	M 4.8 x 0.7	5.5	0.75	4.2	5.8	1.7
0663 4 80*	M 4	8.0	M 4.8 x 0.7	5.5	0.75	4.2	5.8	1.7
0663 5 76	M 5	7.6	M 5.9 x 0.8	7.0	0.75	5.05	7.1	1.8
0663 5 100	M 5	10.0	M 5.9 x 0.8	7.0	0.75	5.05	7.1	1.8
0663 6 94	M 6	9.4	M 7.2x1	8.0	0.75	6.25	8.1	1.8
0663 6 120	M 6	12.0	M 7.2x1	8.0	0.75	6.25	8.1	1.8
0663 7 100	M 7x1	10.0	M 8.25 x 1	8.8	0.75	7.35	8.9	1.9
0663 7 140	M 7x1	14.0	M 8.25 x 1	8.8	0.75	7.35	8.9	1.9
0663 8 117	M 8x1	11.7	M 9.2x1	10.0	0.75	8.2	10.7	2.1
0663 812 511	M 8	11.7	M 9.5x1.25	10.6	0.75	8.2	10.7	2.1
0663 812 516	M 8	16.2	M 9.5x1.25	10.6	0.75	8.2	10.7	2.1
0663 912 513	M 9x1.25	13.0	M 10.5x1.25	11.0	0.75	9.3	11.2	2.1
0663 912 518	M 9x1.25	18.0	M 10.5x1.25	11.0	0.75	9.3	11.2	2.1
0663 101	M 10x1	6.2	M 11.2x1	11.6	0.75	10.3	12.9	2.0
0663 101 90*	M 10x1	9.0	M 11.2x1	11.6	0.75	10.3	12.9	2.0
0663 101 50	M 10x1	15.0	M 11.2x1	11.6	0.75	10.3	12.9	2.0
0663 101 250*	M 10x1.25	9.0	M 11.5x1.25	12.6	0.75	10.3	12.9	2.2
0663 101 251	M 10x1.25	15.0	M 11.5x1.25	12.6	0.75	10.3	12.9	2.2
0663 101 252	M 10x1.25	20.0	M 11.5x1.25	12.6	0.75	10.3	12.9	2.2
0663 101 514	M 10	14.0	M 11.8x1.5	12.6	0.75	10.3	12.9	2.2
0663 101 520	M 10	20.0	M 11.8x1.5	12.6	0.75	10.3	12.9	2.2
0663 111 122*	M 11x1.25	22.0	M 12.4x1.25	13.5	0.75	11.5	14.1	2.6
0663 111 516*	M 11x1.5	16.1	M 12.9x1.5	13.5	0.75	11.5	14.1	2.1
0663 111 522*	M 11x1.5	22.2	M 12.9x1.5	13.5	0.75	11.5	14.1	2.1
0662 121 250	M 12x1.25	9.0	M 13.6x1.25	14.0	0.75	12.1	14.1	2.1
0662 121 251	M 12x1.25	15.0	M 13.6x1.25	14.0	0.75	12.1	14.1	2.1
0663 121 567	M 12x1.5	6.7	M 13.9x1.5	15.0	0.75	12.3	15.1	2.1
0663 121 593	M 12x1.5	9.2	M 13.9x1.5	15.0	0.75	12.3	15.1	2.1
0663 121 516	M 12x1.5	16.3	M 13.9x1.5	15.0	0.75	12.3	15.1	2.1
0663 121 524	M 12x1.5	24.0	M 13.9x1.5	15.0	0.75	12.3	15.1	2.1
0663 121 751	M 12	16.2	M 14.2x1.75	15.0	0.75	12.7	15.4	2.8
0663 121 752	M 12	24.0	M 14.2x1.75	15.0	0.75	12.7	15.4	2.8
0662 141 250	M 14x1.25	7.0	M 15.6x1.25	16.0	0.75	14.0	16.2	2.8
0662 141 251	M 14x1.25	8.0	M 15.6x1.25	16.0	0.75	14.0	16.2	2.8
0662 141 252	M 14x1.25	9.4	M 15.6x1.25	16.0	0.75	14.0	16.2	2.8
0662 141 253	M 14x1.25	11.0	M 15.6x1.25	16.0	0.75	14.0	16.2	2.8
0662 141 254	M 14x1.25	15.0	M 15.6x1.25	16.0	0.75	14.0	16.2	2.8
0662 141 255	M 14x1.25	16.8	M 15.6x1.25	16.0	0.75	14.0	16.2	2.8
0663 141 565	M 14x1.5	6.5	M 15.9x1.5	17.0	0.75	14.7	17.1	2.8
0663 141 593	M 14x1.5	9.3	M 15.9x1.5	17.0	0.75	14.7	17.1	2.8
0663 141 512	M 14x1.5	12.8	M 15.9x1.5	17.0	0.75	14.7	17.1	2.8
0663 141 516	M 14x1.5	16.0	M 15.9x1.5	17.0	0.75	14.7	17.1	2.8
0663 141 526	M 14x1.5	26.0	M 15.9x1.5	17.0	0.75	14.7	17.1	2.8
0663 161 570*	M 16x1.5	7.0	M 17.8x 1.5	18.5	0.75	16.7	19.0	2.9
0663 161 512*	M 16x1.5	12.7	M 17.8x 1.5	18.5	0.75	16.7	19.0	2.9
0663 161 524*	M 16x1.5	24.0	M 17.8x 1.5	18.5	0.75	16.7	19.0	2.9
0663 16 240*	M 16	24.0	M 18.8x 2	19.8	0.75	16.7	20.0	2.9
0663 16 320*	M 16	32.0	M 18.8x 2	19.8	0.75	16.7	20.0	2.9
0663 181 610*	M 18x1.5	10.0	M 19.9x1.5	20.5	0.75	18.3	21.3	3.5
0663 181 518*	M 18x1.5	18.3	M 19.9x1.5	20.5	0.75	18.3	21.3	3.5
0663 181 527*	M 18x1.5	27.0	M 19.9x1.5	20.5	0.75	18.3	21.3	3.5
0663 06 94*	M 6 V2A	9.4	M 7.2x1	8.0	0.75	6.25	8.1	1.8
0663 06 120*	M 6 V2A	12.0	M 7.2x1	8.0	0.75	6.25	8.1	1.8
0663 081 211*	M 8 V2A	11.7	M 9.5x1.25	10.6	0.75	8.2	10.7	2.1
0663 081 216*	M 8 V2A	16.2	M 9.5x1.25	10.6	0.75	8.2	10.7	2.1
0663 011 514*	M 10 V2A	14.0	M 11.8x1.5	12.6	0.75	10.3	12.9	2.2
0663 011 520*	M 10 V2A	20.0	M 11.8x1.5	12.6	0.75	10.3	12.9	2.2

Specifications

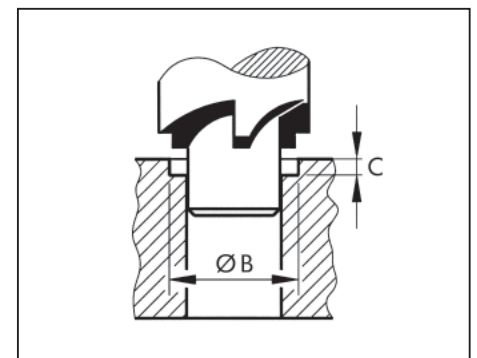
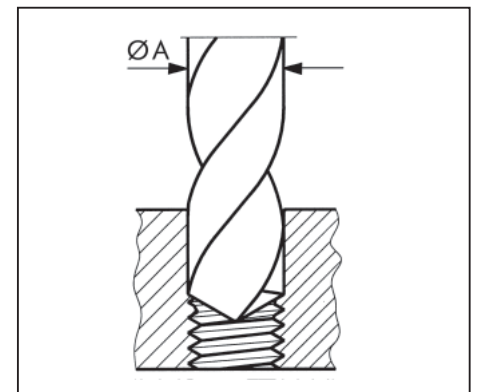
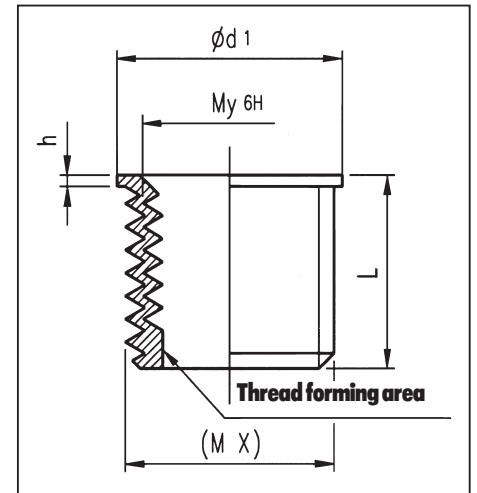

Tear-Out Strength

Depending on the individual case (near edge, material thickness, ...) and material (steel, casting, brass, light metals, ...) the tear-out strength may vary. For that reason, it is not possible to make any general statement, however, tests in the labs of Würth have shown that a repair with TIME-SERT in most cases is equal to the strength of the original thread. The material of the bushes is listed as supplementary information.

Steel Bushes

Material: 9SMn / Pb28K DIN 1651/668
Coating: galvanized, passivated

Stainless Steel Bushes

Material: 1.4301 (V2A) DIN 17440/1654

All dimensions subject to reservations.

* ORSY